



Capacity	Accuracy	Part-Number
200 kg	C3	B8Q-C3-200kg-3B
500 kg	C3	B8Q-C3-500kg-3B
1000 kg	C3	B8Q-C3-1000kg-3B
2000 kg	C3	B8Q-C3-2000kg-3B

Recommended accessories:



Foot BJ-8-202

Foot BJ-8-215

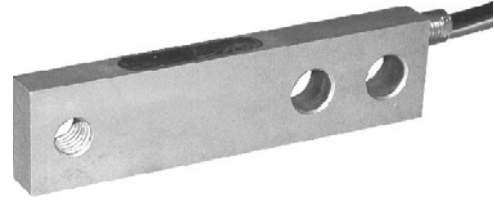
Foot BJ-8-250 for W6 option

- Stainless steel IP67 shear beam load cell
- Low profile
- Suitable for hopper, floor and other electronic scales





Specification:

Accuracy class		C3	OIML R60 C3
Output sensitivity (= FS)	mV/V	2.0 ± 0.002	
Maximum capacity (E _{max})	kg	200	500, 1000, 2000
Maximum number of load cell intervals (n _{LC})		3000	
Ratio of minimum LC verification interval Y = E _{max} / V _{min}	Y	10000	15000
Ratio of minimum dead load output return Z = E _{max} / 2*DR	Z	3000	6000
Combined Error	%FS	≤ ± 0.020	
Safe overload	of E _{max}	150 %	
Ultimate overload	of E _{max}	300 %	
Zero balance	of FS	≤ ± 1.0 %	
Excitation, recommended voltage	V	5 ~ 12	
Excitation maximum	V	18	
Terminal resistance, input	Ω	1106 ± 5	
Terminal resistance, output	Ω	1000 ± 3	
Insulation impedance	MΩ	≥ 5000 (at 50VDC)	
Temperature range, compensated	°C	-10 ~ +40	
Temperature range, operating	°C	-35 ~ +65	
Element material		Stainless steel	
Recommended torque on fixation bolts	Nm	100	
Ingress Protection (according to EN 60529)		IP67	

Outline Dimensions in mm

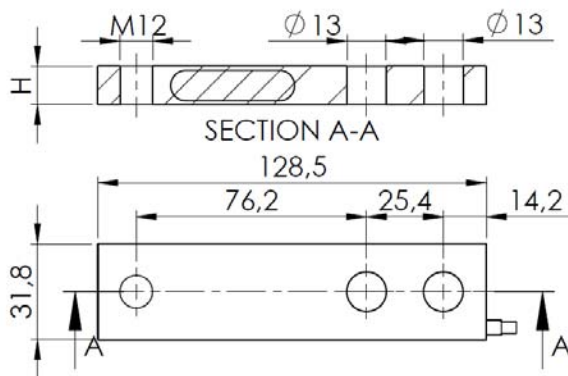
Standard version



W6 option

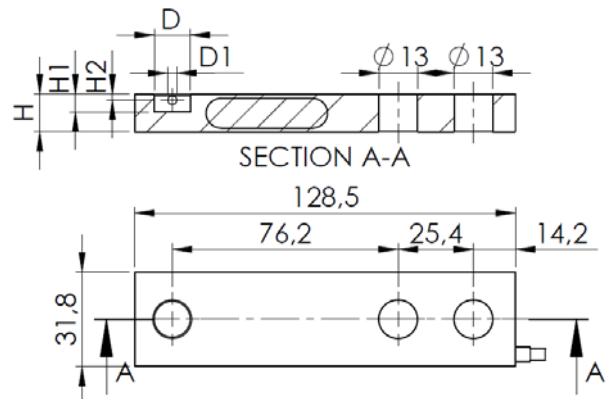

Capacity	H	H1	H2	D	D1
200 kg	12.7	6	2	Ø12.1	Ø3
500 kg	15.9	9.5	2.8	Ø18.1	Ø4
1000 kg	19.1	9.5	2.8	Ø18.1	Ø4
2000 kg	25.4	9.5	2.8	Ø18.1	Ø4

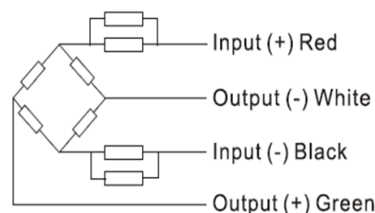

Wiring:

Shielded, 4 conduct cable: φ 5.0mm
 Standard cable length: 3m
 Shield not connected to body